

性能优势 PERFORMANCE ADVANGATE

1. 阀体采用精密铸造工艺，先进的工艺了确保阀体无砂眼，表现光滑，质量更可靠。
The valve body adopts investment casting technology. Advanced technology to ensure that the valve body has no sand holes, surface more smooth and quality more reliable.
2. 堆焊阀座，即使在恶劣工况下，也能确保可靠的密封。
Overlay welded seat can keep reliable sealing under severe conditions.
3. 人体工程学设计手轮，使用寿命更长，操作轻松便捷且安全可靠。
Ergonomic hand wheel. It provide longer service life and easier Operation.

设计特征 DESIGN FEATURE

明杆Rising stem 明杆支架式OS&Y
螺栓阀盖Bolt bonnet 活动闸板Flexible wedge

技术规范 TECHNICAL SPECIFICATION

设计标准Design standard: DIN EN 13709:2003
结构长度Face to face dimension: DIN EN 558-1:1995
连接法兰Flanged ends: DIN EN 1092-1:2002
对焊连接Welded ends: DIN EN 12627
试验与检验Test & inspection: DIN EN 12266:2003

应用 APPLICATION

热油系统、蒸汽系统、冷热水系统等等
Thermal oil system, steam system, hot and cold water system etc.

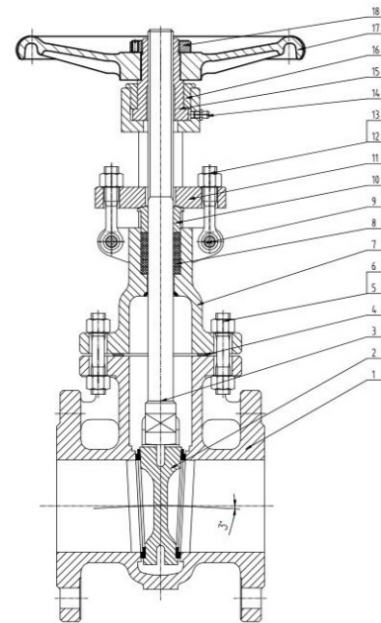

产品零部件材料 PRODUCT PARTS AND MATERIALS

序号/No.	零件名称 Parts Name	材质 Materials		
1	阀体 Body	GS-C25/1.0619+13Cr	CF8/1.4301	CF8M/1.4408
2	阀瓣 Disc	GS-C25+13Cr	SS304	SS316
3	阀杆 Stem	X20Cr13	SS304	SS316
4	垫片 Gasket	Graphite+SS	Graphite+SS	Graphite+SS
5	螺栓 Bolt	A193 B7	A193 B8	A193 B8M
6	螺母 Nut	A194 2H	A194 8	A194 8M
7	阀盖 Bonne	GS-C25/1.0619	CF8/1.4301	CF8M/1.4408
8	填料 Packing	Graphite	Graphite	Graphite
9	插销 Pin	SS410	SS410	SS410
10	压盖 Gland	A105	SS304	SS316
11	压盖法兰 Gland flange	WCB	SS304	SS316
12	螺栓 Bolt	A193 B7	A193 B8	A193 B8M
13	螺母 Nut	A194 2H	A194 8	A194 8M
14	油嘴 Grease Nipple	H2	H2	H2
15	阀杆螺母 Stem nut	Ductile iron	Copper alloy	Copper alloy
16	轴承盖 Bearing cover	A105	SS304	SS316
17	手轮 Hand wheel	Steel	Steel	Steel
18	锁紧螺母 Lock nut	SS410	SS410	SS410

备注Notes: 以上零件为常规产品材质，如有特殊要求，可根据客户要求变动，如密封面为司太立。
Above parts materials are used for conventional product. If there are special requirements, which can be changed according to customer requirements. For example, the sealing can be Stellite.

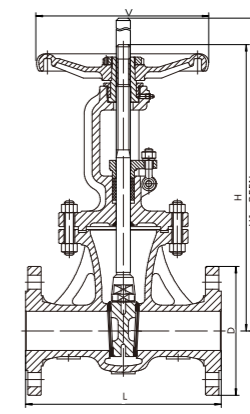
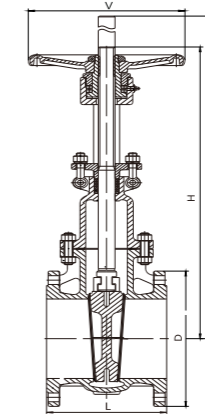

主要连接尺寸MAIN DIMENSIONS(mm)

		Fig.VK511 PN10/16—F4系列																	
口径 Size DN		50	65	80	100	125	150	200	250	300	350	400	450	500	600	700	800	900	1000
总长 L RF/BW		150	170	180	190	200	210	230	250	270	290	310	330	350	390	430	470	510	550
手轮 W		160	180	180	200	220	220	250	300	350	400	450	450	450	450	500	600	-	-
中心高 H		350	420	500	520	610	700	900	1050	1200	1400	1580	1700	1900	2300	2600	3200	-	-
全开高 H1		415	495	580	620	720	840	1100	1300	1540	1750	1980	2150	2450	3000	3500	4100	-	-
重量 kg		17	22	27	38	53	68	108	160	220	275	390	487	560	850	1250	1830	2290	3700
		Fig.VK512 PN16—F5系列																	
口径 Size DN		50	65	80	100	125	150	200	250	300	350	400	450	500	600	700	800	900	1000
总长 L RF/BW		250	270	280	300	325	350	400	450	500	550	600	650	700	800	900	1000	1100	1200
手轮 W		200	200	250	280	300	360	360	400	450	500	500	600	600	680	-	-	-	-
中心高 H		400	420	500	520	610	620	780	1050	1200	1400	1580	1750	1900	2300	2600	3200	4400	4700
全开高 H1		470	495	580	620	720	760	980	1300	1540	1750	1980	2200	2450	3000	3500	4100	5500	5900
重量 kg		22	25	38	45	72	95	165	250	330	470	570	810	1180	1450	1800	2400	3050	3900
		Fig.VK513 PN25—F5系列																	
口径 Size DN		50	65	80	100	125	150	200	250	300	350	400	450	500	600	700	800	900	1000
总长 L RF/BW		250	270	280	300	325	350	400	450	500	550	600	650	700	800	900	1000	1100	1200
手轮 W		200	200	250	280	300	360	360	400	450	500	500	600	600	680	-	-	-	-
中心高 H		400	420	500	520	610	620	780	1050	1200	1400	1580	1750	1900	2300	2600	3200	4400	4700
全开高 H1		470	495	580	620	720	760	980	1300	1540	1750	1980	2200	2450	3000	3500	4100	5500	5900
重量 kg		24	28	40	50	76	108	180	280	350	490	650	920	1250	1560	2030	2550	3870	4500
		Fig.VK514 PN40—F7系列																	
口径 Size DN		50	65	80	100	125	150	200	250	300	350	400	500	600	700	800	900	-	-
总长 L RF/BW		250	290	310	350	400	450	550	650	750	850	950	1150	1350	1550	1750	1950	-	-
手轮 W		200	250	250	300	300	360	400	450	500	600	600	650	750	800	900	1000	-	-
中心高 H		377	390	418	489	541	630	824	915	1085	1190	1310	1560	1875	-	-	-	-	-
全开高 H1		427	455	500	590	665	780	1024	1165	1385	1540	1710	2070	2475	-	-	-	-	-
重量 kg		25	33	45	59	78	116	225	360	515	710	950	1300	2100	3020	-	-	-	-
		Fig.VK515 PN63—F7系列																	
口径 Size DN		50	65	80	100	125	150	200	250	300	350	400	500	600	-	-	-	-	-
总长 L RF/BW		250	290	310	350	400	450	550	650	750	850	950	1150	1350	-	-	-	-	-
手轮 W		200	250	250	300	300	360	400	450	500	600	600	700	800	-	-	-	-	-
中心高 H		450	500	540	670	685	810	970	1155	1330	1500	1680	2100	2400	-	-	-	-	-
全开高 H1		500	570	620	780	810	980	1180	1420	1660	1880	2100	2650	3100	-	-	-	-	-
重量 kg		32	39	53	78	123	176	340	435	560	843	1310	1900	3700	-	-	-	-	-